

Installation Instructions

Joint System: 1200

PLEASE READ ALL INSTRUCTIONS
BEFORE INSTALLATION

These instructions are intended as recommended guidelines. Due to the variability of field conditions, selection of the proper material for the intended application and installation are the sole responsibility of the applicator. The manufacturer's published installation procedures shall be followed at all times.

Recommended Tools

Tape Measure, Sharp Knife, Miter Saw, Blue Painters Tape, Mineral Spirits, Clean Cloth, Isopropyl Alcohol or Acetone, Caulking Tool, Wood Wedges and Propane Torch.

Material Sizing

1. Joints must be sized every 5-7 feet (1.5-2 meters) to ensure gap opening is uniform and depth is sufficient for the supplied material.

Material Preparation

Tip: Material will expand faster when hot and slower when cold. In cold temperatures, store material in a heated area 24 hours prior to installation. In hot temperatures, store material out of direct sunlight and not in an enclosed storage container where temperatures may exceed 100°F.

1. Store material at a minimum of 68°F (20°C) for a minimum of 24 hours prior to installation, regardless of temperature at location of installation.

2. Store materials in a dry, enclosed area. Make sure materials are off the ground and out of direct sunlight.

3. Use a saw to make any cuts to the seal before removing the clear shrink packaging. All starting and ending pieces must be square to the termination point.

Tip: Apply mineral spirits to the knife for a smoother cut or heat blade with propane torch for easy cuts.

Joint Preparation

1. Verify that the joint is clean, sound, and will provide an appropriate surface for installation of the joint sealant. Use compressed air to clean any loose debris from the joint. Apply alcohol to a clean cloth and wipe the joint walls to the depth of the foam material plus 1".

2. Verify that the joint is uniform and repair any spalls prior to installation. Rectify voids and form marks as well.

3. Apply blue painters tape to both edges of the substrate face to prevent the silicone from contacting the deck surface.

4. Check the material for appropriate length, width, and depth. Joint depth must allow the installed material to be recessed 1/8"-1/4" from the joint face, or more per project requirements.

Important Notes on Pre-Compressed Foam Seal:

Material is made to order, keeping pre-compressed foam in storage for longer than 2 weeks will greatly increase the amount of time required for the foam seal to reach maximum expansion.

NOTE: Material may take up to 72 hrs. to fully expand.

NOTE: Do not install when substrate or ambient temperatures are below 32°F (0°C) or above 95°F (35°C).

Fig 1

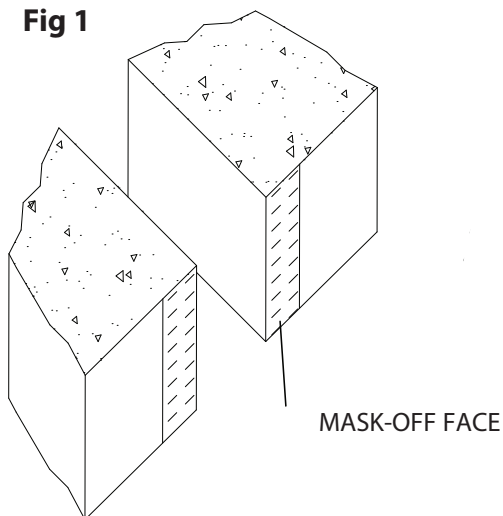

Installation - Figs. 1-6

1. For vertical joints, begin installation at the bottom of the joint and work upward. The installed sticks will support the subsequent sticks until the material fully expands.

IPC.930/Rev.6

JOINTMASTER® Expansion Joint Systems

inpro.com • 800.222.5556 • 262.679.9010

World Headquarters S80 W18766 Apollo Drive, Muskego, WI 53150 USA

Installation Hotline: 866.394.6776

inpro®

Installation Instructions

Joint System: 1200

PLEASE READ ALL INSTRUCTIONS
BEFORE INSTALLATION

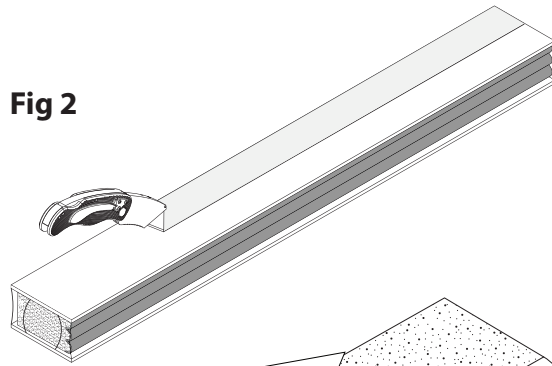
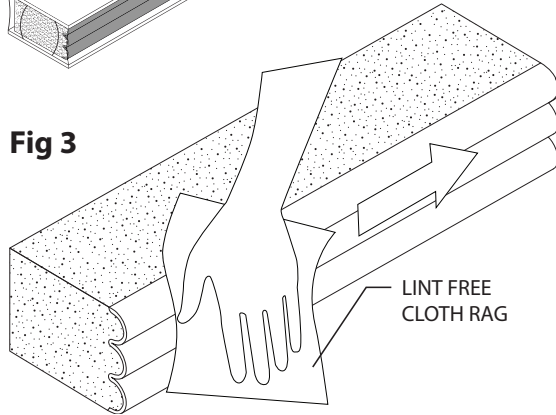
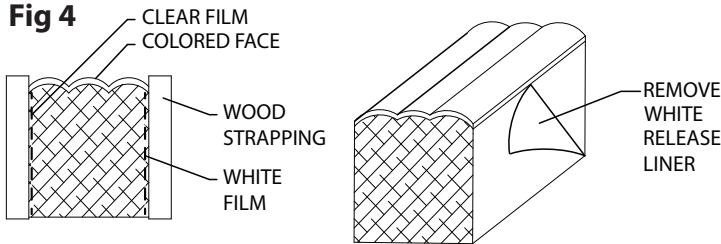

Fig 2



LINT FREE
CLOTH RAG

Fig 4



PRE-COMPRESSED
JOINT SEALANT

Fig 5a

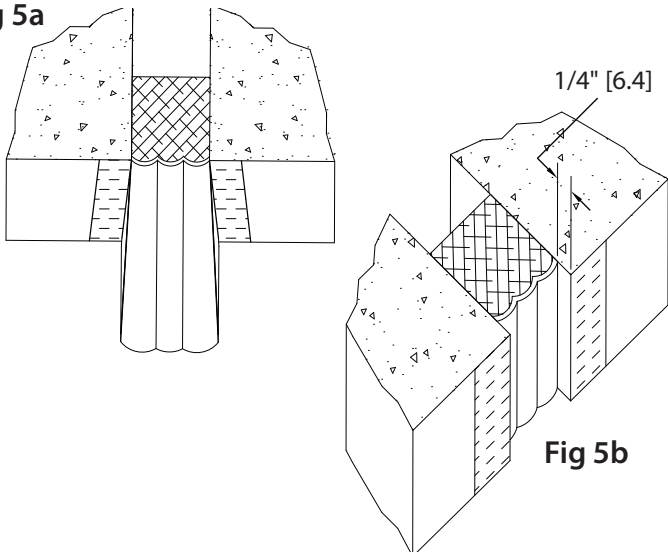

Fig 5b

2. When fully prepared to install, open the sealant material by cutting the shrink packaging along the sides of the masonite strapping. **See Fig. 2**

Note: Seals for joints smaller than 6" [152mm] will have a white film on one side, and a clear film on the other side.

Warning: Do not cut the colored face of the material, and be prepared to install the material immediately once the packaging is removed to prevent the material from expanding past the joint width.

3. (Not required for uncoated material) Silicone face may be coated in the factory with a powder release agent. Prior to installation, this agent must be wiped off in order for the finish bead to properly adhere along the edge of the 1200 system. **See Fig. 3**

To remove the powder, lightly, quickly, and thoroughly wipe the cured silicone facing with a lint-free rag dampened with water.

4. Verify that the material is cut square at both ends for proper seams. All pieces must be square to the termination point.

5. For joints with a nominal size smaller than 6" [152mm], apply a continuous bed of the supplied silicone caulk full depth of seal on the side of the joint to receive the clear film side.

6. Remove the white release liner on the side of the seal. **See Fig. 4**

7. Place the material into the joint while gently pushing the pressure sensitive adhesive (white film side) up against one side of the joint. Remove clear release liner and allow the material to expand and fill the joint, shim as required if foam expands unevenly. **Note:** If the PSA is hampering installation, use a spray bottle to wet the adhesive surface of the seal (will not affect the final sealing properties).

8. Installed material to be recessed 1/4" [6mm] from joint face, or per project requirements. **See Fig. 5b**

JOINTMASTER® Expansion Joint Systems

inpro.com • 800.222.5556 • 262.679.9010

World Headquarters S80 W18766 Apollo Drive, Muskego, WI 53150 USA

Installation Hotline: 866.394.6776

inpro®

Installation Instructions

Joint System: 1200

PLEASE READ ALL INSTRUCTIONS
BEFORE INSTALLATION

Fig 6

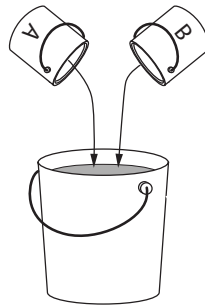

9. When the joint is 6" [152mm] or above, install the foam with epoxy. Read cans for mixing instructions. Pot life is 30 minutes, only mix one kit at a time, and always mix a full kit. **See Fig. 6.** Apply epoxy to both sides of the substrate inside the throat of the joint. Use trowel, brush, or gloved hand to apply epoxy.

Note: For every +17°F [9.5°C] epoxy cures twice as fast; while every -17°F [9.5°C] epoxy cure time doubles.

Warning: NEVER thin the epoxy. Reference epoxy data sheet for storage info and temp range as well as usage temp ranges.

Note: Epoxy will harden faster when left in the mixing pot, because of that, apply epoxy to the joint as soon as possible to slow the curing time.

Warning: Allow 72 hours for full expansion and material equalization. Expansion and equalization rates are affected by temperature.

Fig 7a

Fig 7b

Fig 7c

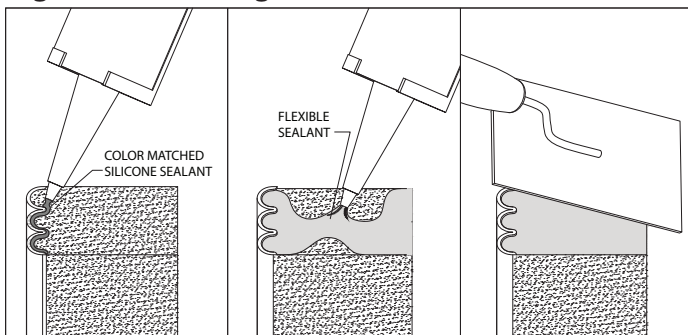

NOTE: Joint substrate not shown to aid in clarity only

Seams - Figs. 7-9

1. If installing more than one length of foam seal, verify that the new piece of material is cut square and not at an angle to the previous material installed.

Tip: Apply mineral spirits to the knife for a smoother cut or heat blade with propane torch for easy cuts.

2. After the first foam seal is installed to the proper depth, apply flexible sealant to the butt end of the new piece of material.

3. Run a continuous bead of supplied color matched silicone along the edge of the silicone bellows. **See Fig. 7a**

4. For joints smaller than 6" [152mm], apply the supplied silicone to the butt end of the new piece. For joints 6" [152mm] and above, apply the supplied flexible sealant on the end of the installed foam seal, ensuring to completely entomb end in sealant. **See Fig. 7b**

5. Flatten the sealant to an even 1/16th [2mm] thickness. **See Fig. 7c**

***Critical*:** All seams must be in compression with previous seal. Install with 1/2"-3/4" [12-18mm] compressed overlap. **See Fig. 8**

Note: Best practice is to lay the next piece flat over the joint, overlapping your previously installed piece, then mark the starting point. Install the far end at the mark and work back towards the previous piece.

Fig 8

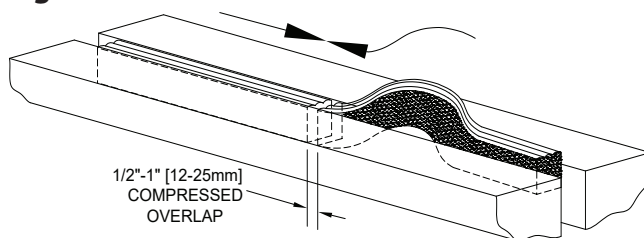

Installation Instructions

Joint System: 1200

PLEASE READ ALL INSTRUCTIONS
BEFORE INSTALLATION

Fig 9

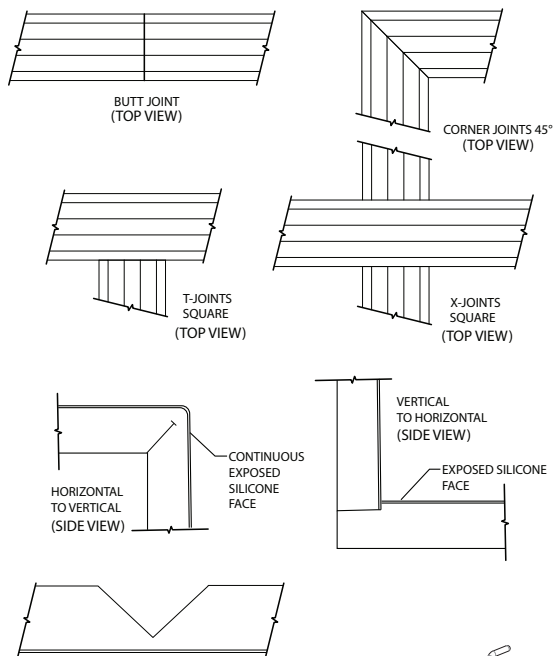

Fig 10

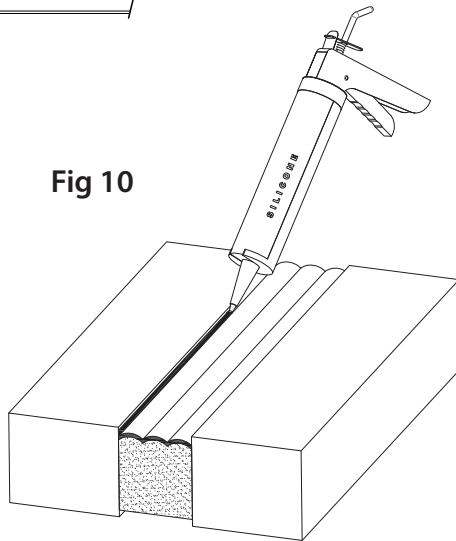
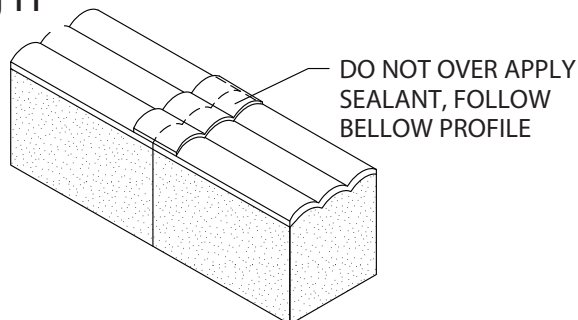

Fig 11



NOTE: Joint substrate not shown to aid in clarity only

Tip: Apply mineral spirits to the knife for a smoother cut or heat blade with propane torch for easy cuts.

6. "T" and "+" Intersections:

Install the longer run of material first. Butt the intersecting material up to the first run of material following steps 1+2.

Note: After installation, if there are any mitered joints with a hole or a void, use the supplied silicone to fill and seal the joint.

7. Horizontal To Vertical Intersections: (Outside Corner)

Begin the installation at the horizontal condition. At the point of transition cut a V-notch in the back of the foam seal, making sure not to cut through the face of the seal. Fold foam seal downward, and continue installation.

8. Vertical to Horizontal Intersections: (Inside Corner)

Starting at one end, cut and remove the silicone face of the horizontal foam seal to create a matching notch for the vertical seal to seat in. Install horizontal seal, then continues installing vertical seal.

Finish - Figs. 10 - 11

1. Install a bead of color matching silicone along each edge of the joint to fill any irregularities in the substrate.
1. Tool the silicone over all seams and transitions using a small caulking tool.
2. Evenly spread the silicone on exposed seams to allow for a clean, aesthetic finish.

Important: When siliconing seams at face seal, ensure bellow profile is carefully followed to allow joint to flex.
See Fig. 8b

3. Remove any excess silicone left on the surface of the material or substrate.

Warning: Do not allow the silicone to cure before removal.
4. Remove the blue painters tape from the substrate surface.