

151-A02-025

SPECIFY SEAL COLOR:	
Black (J1D101)	
Beige (J1D102)	
Gray (J1D103)	
Off White (J1D104)	
Bright White (J1D105)	

JOINT WIDTH		MOVEMENT ±			
		HORIZONTAL		VERTICAL	
US	mm	US	mm	US	mm
1"	25	1/4"	6	1/4"	6

NOTE:
TO DETERMINE BLOCKOUT DEPTH, DEDUCT THICKNESS OF FIN. FLR. FROM FRAME HEIGHT.

FINISH: ALUM FINISH: MILL
PROJECT:
CUSTOMER:
LOCATION:

APPLICATION-
RECESSED FLOOR/FLOOR CONDITION

DATE:	12/30/14
SCALE:	1:2
DOC:	CADJM.155/R2

inpro.

For More Information Visit: Inprocorp.com

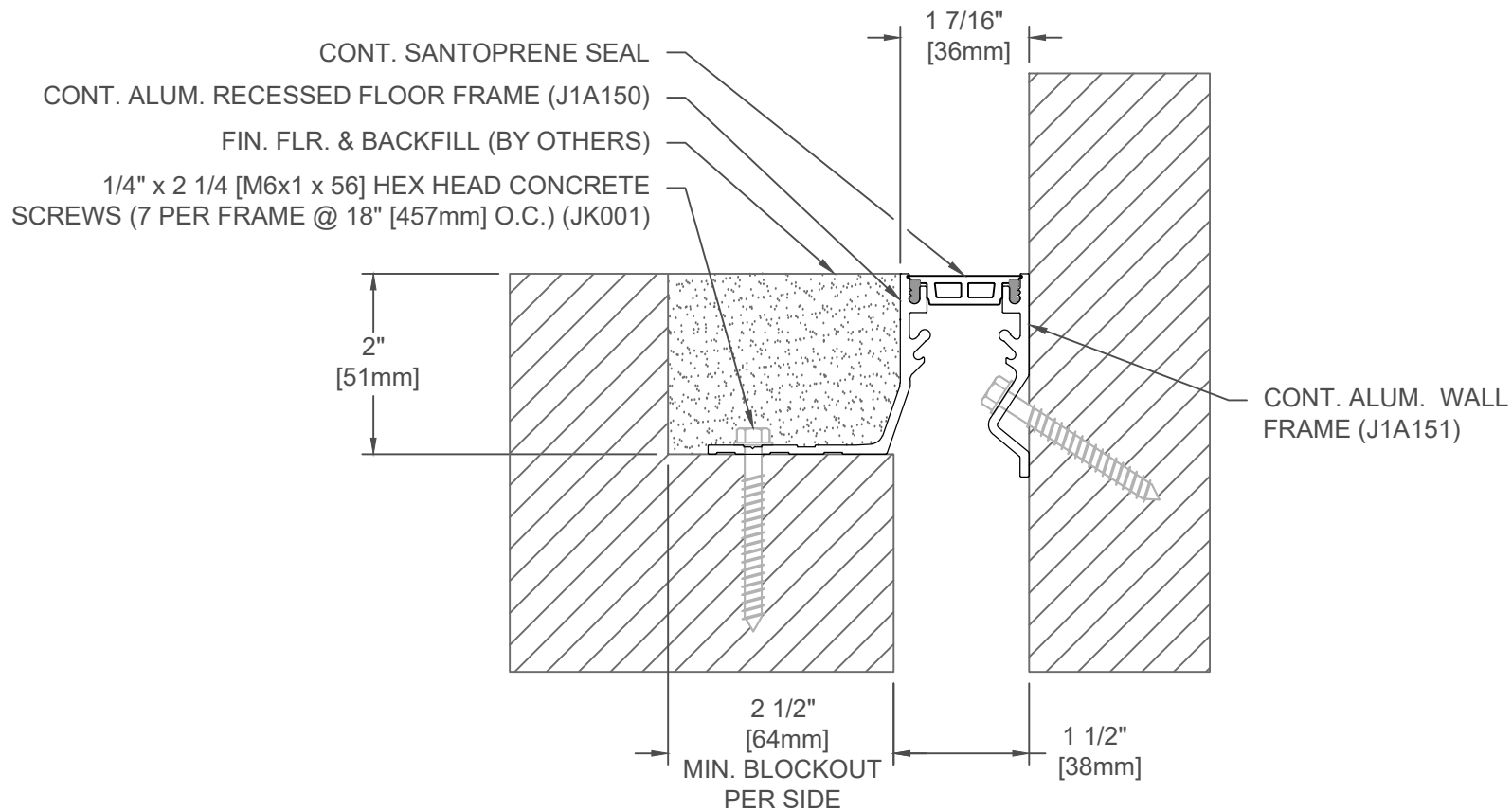

SPECIFY SEAL COLOR:	
Black (J1D151)	
Beige (J1D152)	
Gray (J1D153)	
Off White (J1D154)	
Bright White (J1D155)	

151-A02-038

JOINT WIDTH		MOVEMENT ±			
		HORIZONTAL		VERTICAL	
US	mm	US	mm	US	mm
1 1/2"	38	3/8"	10	3/8"	10

NOTE:
TO DETERMINE BLOCKOUT
DEPTH, DEDUCT THICKNESS OF
FIN. FLR. FROM FRAME HEIGHT.

FINISH: ALUM FINISH: MILL

PROJECT:

CUSTOMER:

LOCATION:

APPLICATION-
RECESSED FLOOR/FLOOR CONDITION

DATE: 12/30/14

SCALE: 1:2

DOC: CADJM.155/R2

inpro.

For More Information Visit: Inprocorp.com

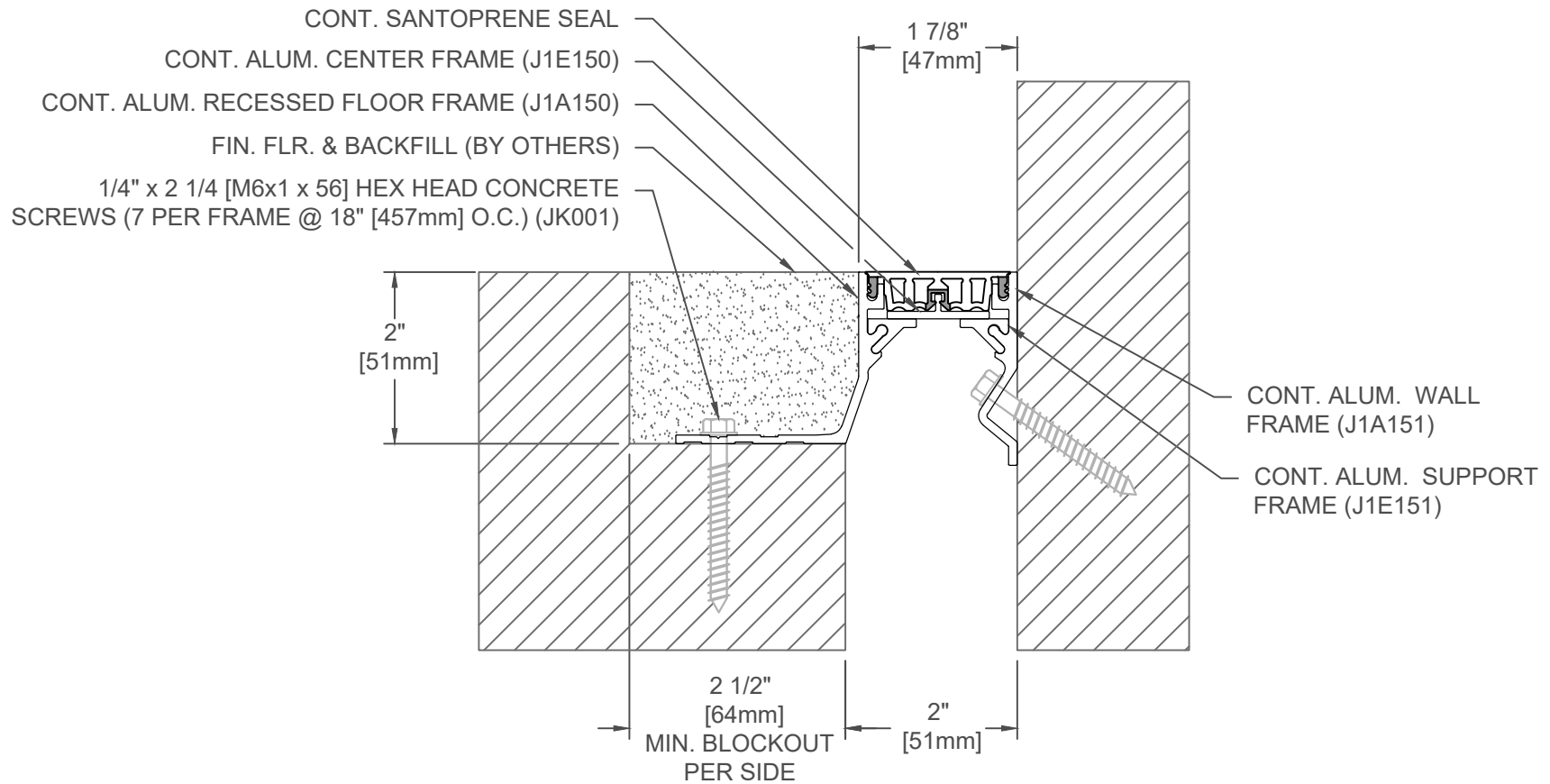

151-A02-050

SPECIFY SEAL COLOR:	
Black (J1D201)	
Beige (J1D202)	
Gray (J1D203)	
Off White (J1D204)	
Bright White (J1D205)	

JOINT WIDTH		MOVEMENT ±			
		HORIZONTAL		VERTICAL	
US	mm	US	mm	US	mm
2"	51	1/2"	13	1/2"	13

NOTE:
TO DETERMINE BLOCKOUT DEPTH, DEDUCT THICKNESS OF FIN. FLR. FROM FRAME HEIGHT.

FINISH: ALUM FINISH: MILL

PROJECT:

CUSTOMER:

LOCATION:

APPLICATION-
RECESSED FLOOR/FLOOR CONDITION

DATE: 12/30/14

SCALE: 1:2

DOC: CADJM.155/R2

inpro.

For More Information Visit: Inprocorp.com

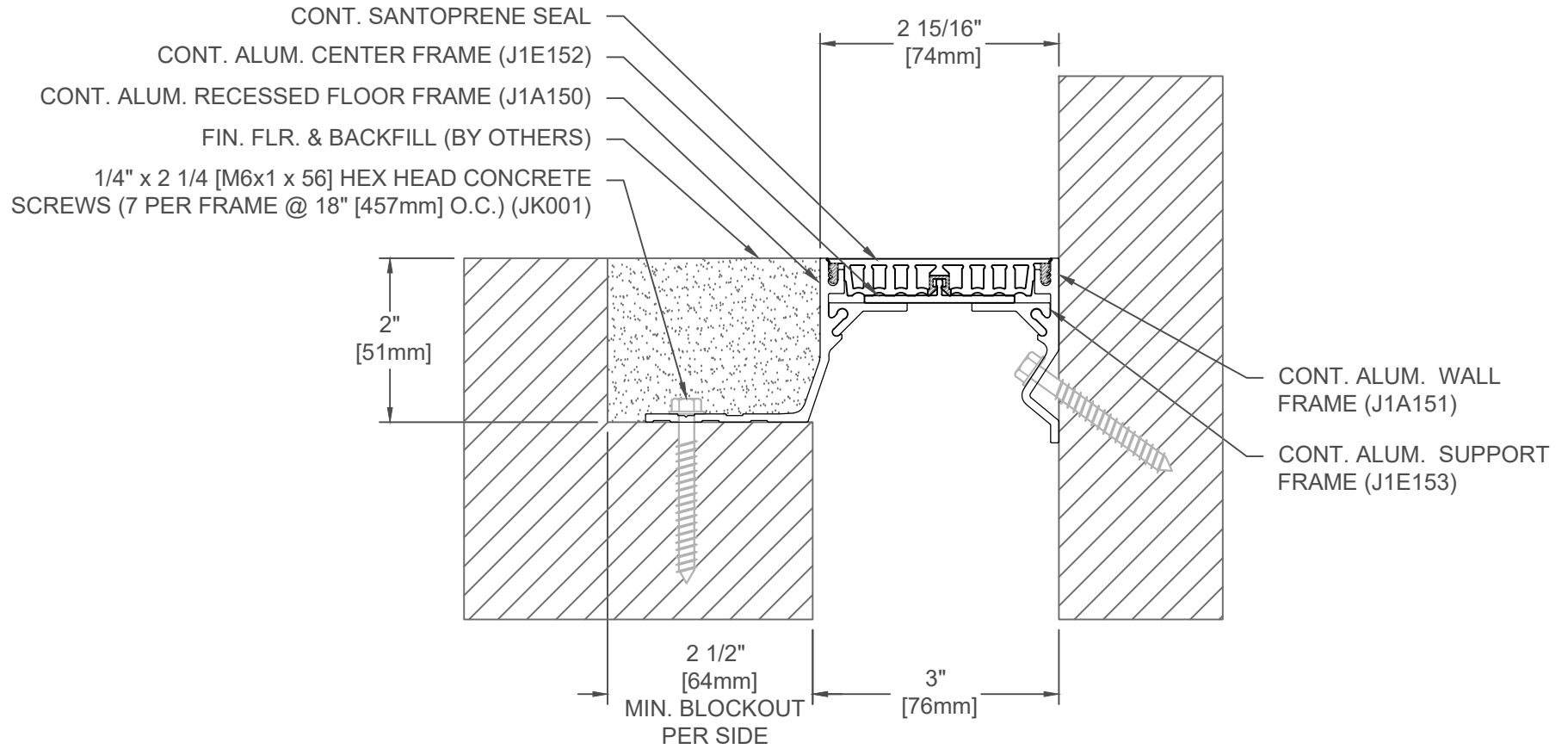

151-A02-075

SPECIFY SEAL COLOR:	
Black (J1D301)	
Beige (J1D302)	
Gray (J1D303)	
Off White (J1D304)	
Bright White (J1D305)	

JOINT WIDTH		MOVEMENT ±			
		HORIZONTAL		VERTICAL	
US	mm	US	mm	US	mm
3"	76	3/4"	19	3/4"	19

NOTE:
 TO DETERMINE BLOCKOUT DEPTH, DEDUCT THICKNESS OF FIN. FLR. FROM FRAME HEIGHT.

FINISH: ALUM FINISH: MILL

PROJECT:

CUSTOMER:

LOCATION:

APPLICATION-
 RECESSED FLOOR/FLOOR CONDITION

DATE: 12-15-17

SCALE: 1:2

DOC: CADJM.155/R2

inpro.

For More Information Visit: Inprocorp.com