

Installation Instructions

Joint System: 651-A09

Note: Verify that the structural gap is in conformance with submittal data before beginning installation. If this is a Fire Rated Assembly, install the fire barrier before the Architectural Joint System. Refer to the fire barrier instructions for specific system installation.

Fig. 1

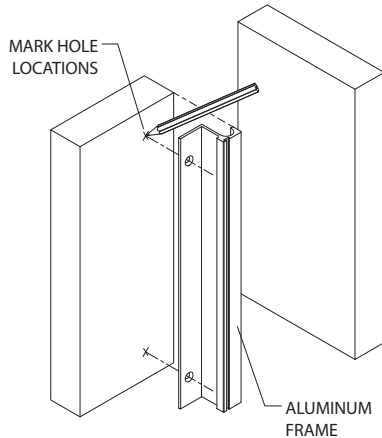

1. Install the architectural joint system on a level wall surface. This may require leveling to raise the tops of the frames.

Figure 1

2. Cut the aluminum frame to the desired length.
3. Align the front face of the frame with the structural gap. The radius profile of the frames should be facing the structural gap. Align front face of frame plumb to edge of structural gap.
4. Mark the pre-drilled hole locations on the substrate and remove the frames from the wall.

Fig. 2

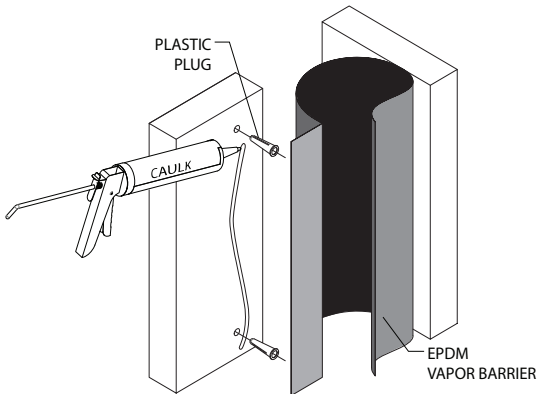

Figure 2

5. Drill all marked holes on the wall using a 1/4" (6mm) drill bit to 1 1/2" (38mm) depth. Insert plastic plug anchors into drilled holes.
6. Lay continuous bead of butyl caulk (contractor furnished) on face of wall. Starting from the top of the joint opening, place vapor barrier evenly over wall substrate allowing the excess material to drape into the structural gap. If necessary, vapor barrier may be fastened to substrate with nails. Fold ends up or weep out.

Fig. 3

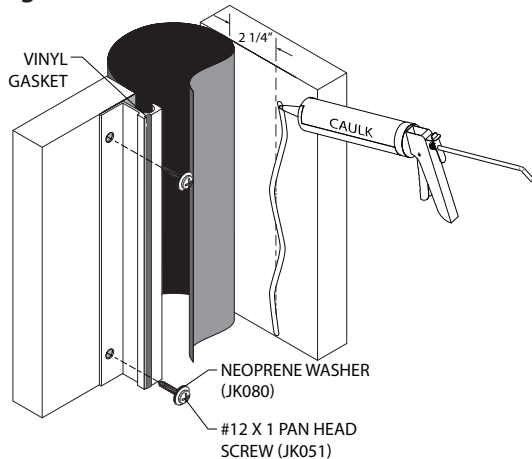

Figure 3

7. Lay a continuous bead of butyl caulk 2 1/4" above the face of opposing wall. Repeat step 6 for opposing wall.
8. Return aluminum frames to edge of structural gap. Fasten aluminum frames to wall surface using supplied fasteners.
9. Slide vinyl gasket into frames

IPC.1299/REV.3

JOINTMASTER® Expansion Joint Systems

inpro.com • 800.222.5556 • 262.679.9010

World Headquarters S80 W18766 Apollo Drive, Muskego, WI 53150 USA

Installation Hotline: 866.394.6776

inpro®

Installation Instructions

Joint System: 651-A09

Fig. 4

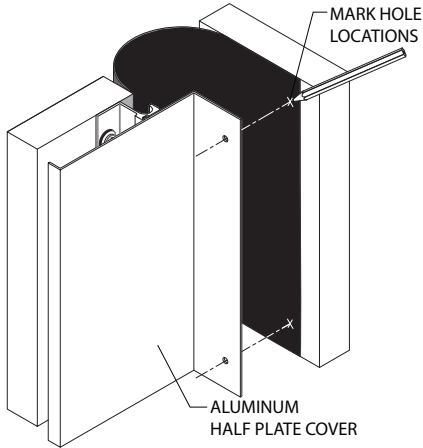

Fig. 5

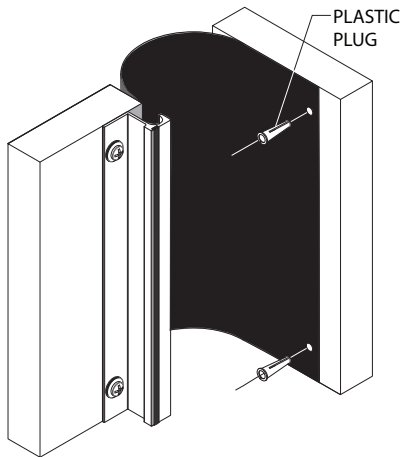

Fig. 6

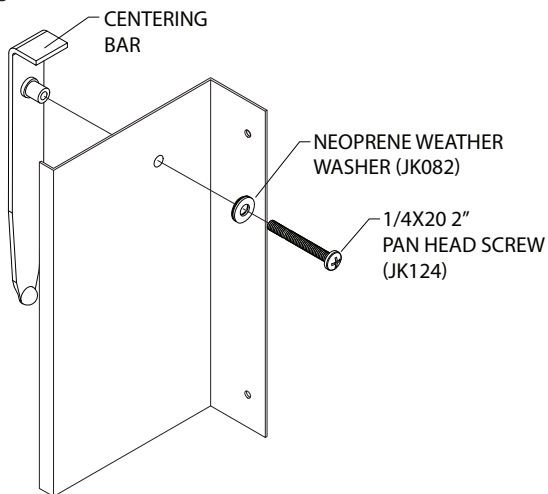

Figure 4

8. Place the half plate over the structural gap with the 2" (52 mm) straight leg (pre-drilled hole side) firmly against the wall. Rest the horizontal base leg of the half plate firmly on the frame's vinyl gasket. Align parallel to the wall

9. Mark hole locations on substrate using pre-drilled holes in the half plate. Remove the plate from the joint gap.

Figure 5

10. Drill all marked hole locations on the wall using a 1/4" (6mm) drill bit to 1 1/2" (38mm) depth. Insert plastic plug anchors into drilled holes.

Figure 6 (For joint widths larger than 6" (152mm))

11. Assemble the provided JK125 1/4-20 x 2" pan head machine screws with one JK080 neoprene washer per screw. Insert the assembled hardware through the predrilled holes on the cover plate.

12. Loosely thread the provided centering bars (7 per length) on to the JK124. Ensure all centering bars are facing down when positioning the cover plate over the joint opening.

Installation Instructions

Joint System: 651-A09

Fig. 7

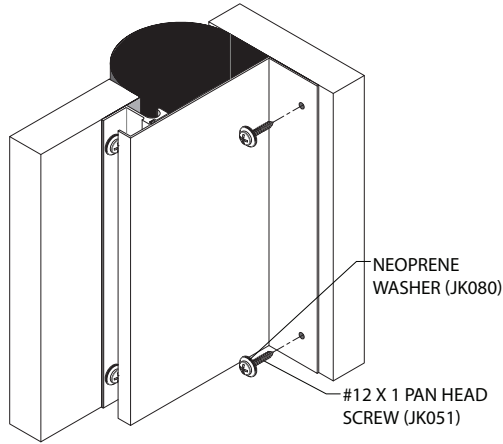

Figure 7

- Return aluminum half plate over structural gap. Resting the horizontal base leg of the half plate firmly on the frame's vinyl gasket. Fasten aluminum half plate to wall surface using supplied fasteners. (If using centering bars ensure all centering bars are facing downward)

Figure 8

- Clean exposed surface with non-solvent cleaner, such as 409, as required

Fig. 8

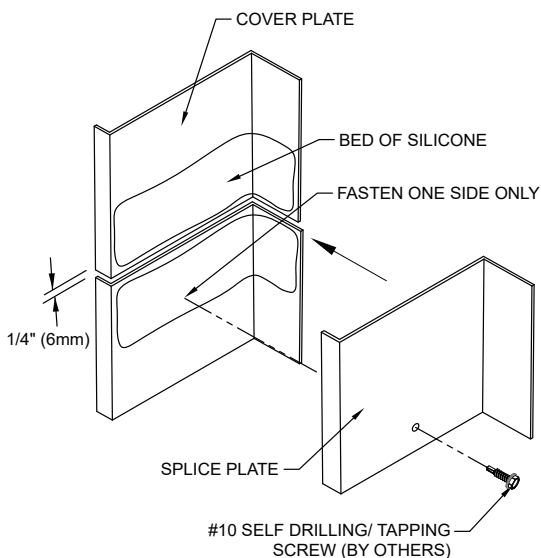
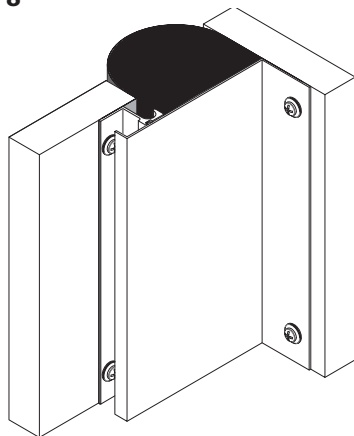

Splice Plate Installation Instructions

- Leave a min. of 1/4" (6mm) gap between the full sections
- Apply a bed of continuous silicone sealant (contractor furnished) to splice plate over seam to ensure a water tight seal.
- Fasten a min. of one #10 (5mm) self drilling/ tapping screw, 1" (25mm) (contractor furnished) in from the center top of the splice plate on one side. Do not fasten both ends of the splice plate

JOINTMASTER® Expansion Joint Systems

inpro.com • 800.222.5556 • 262.679.9010

World Headquarters S80 W18766 Apollo Drive, Muskego, WI 53150 USA

Installation Hotline: 866.394.6776

inpro®