

Installation Instructions

Joint System: 672-G01

Note: Verify that the structural gap is in conformance with submittal data before beginning installation. If this is a Fire Rated Assembly, install the fire barrier before the Architectural Joint System. Refer to the fire barrier instructions for specific system installation.

Fig. a

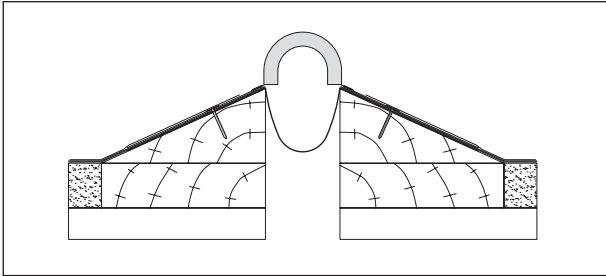

Fig. 1

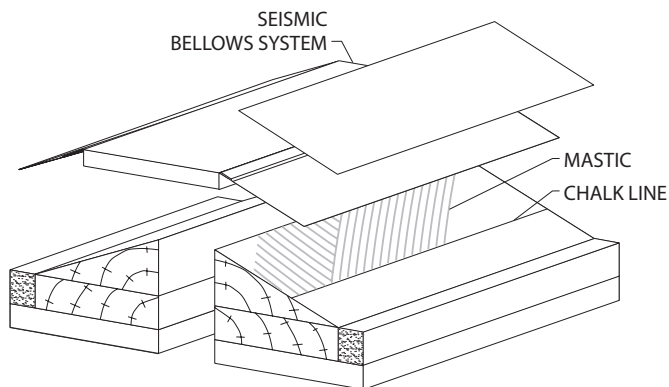
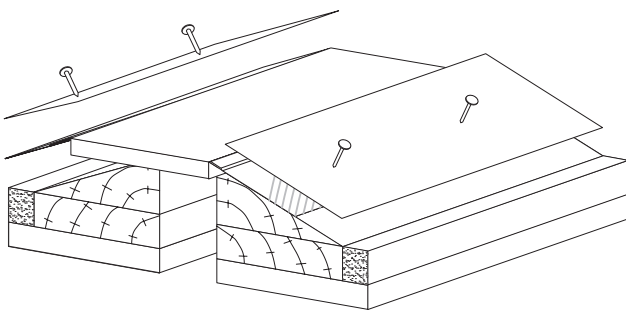

Fig. 2



1. Snap a chalk line 4" (100mm) from each side of the joint opening. For joint openings over 8" (203mm) wide, snap a chalk line at 4 1/2" (114mm).

a. Optional EPDM Vapor Barrier: Trowel membrane compatible mastic (contractor furnished) to the chalk line on both sides of the joint opening. Starting from one end, embed one side of the vapor barrier in mastic to the chalk line. Repeat on opposite side, allowing excess material to drape into the joint opening. If necessary, vapor barrier may be fastened to the substrate with roofing nails. Fold ends up or weep out. (see Figure a)

Figure 1

2. Locate and install all intersections (corners, tees and crossovers) and transitions first. Trowel membrane compatible mastic (contractor furnished) to the chalk line at these locations. Embed flanges in mastic and nail in place using contractor furnished 1 1/4" (31mm) roofing nails at 2" - 4" (50mm-100mm) centers.
3. To allow for expansion, cut slots in galvanized flanges at 50' intervals. For aluminum, stainless steel and copper flanges, slots should be cut at 25' intervals.

Figure 2

4. Trowel membrane compatible mastic (contractor furnished) on one side of the joint opening to the chalk line. Place bellows at roof edge and set one flange in position on mastic to chalk line, leaving 1/2" (12mm) space between intersections/transitions and all succeeding sections. Nail flange using contractor furnished 1 1/4" (31mm) roofing nails, 4" (100mm) on center starting 1" (25mm) from each end.

IPC.866/REV.2

Installation Hotline • 866.EZINPRO
Inprocorp.com • 800.222.5556 • 262.679.9010
World Headquarters S80 W18766 Apollo Drive, Muskego, WI 53150 USA

JOINTMASTER™
EXPANSION JOINT SYSTEMS

Installation Instructions

Joint System: 672-G01

Fig. 3

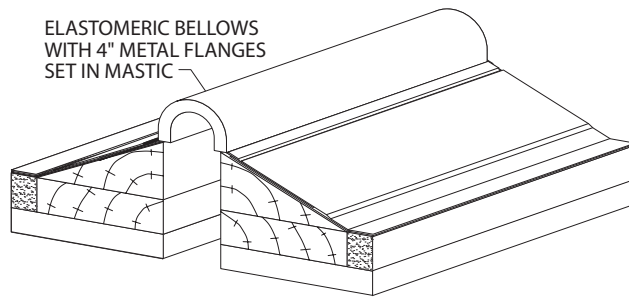

Fig. 4

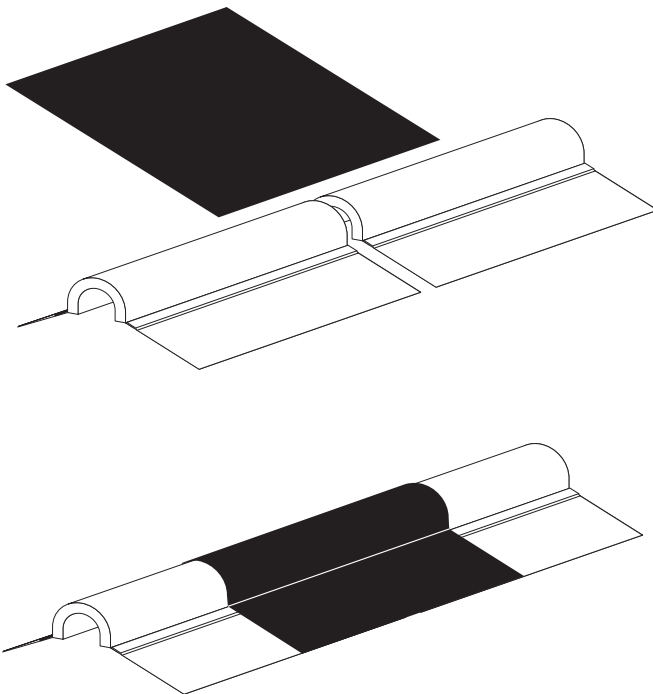

Figure 3

5. Trowel membrane compatible mastic on opposite side of the joint opening to the chalk line. Squeeze bellows and embed opposite flange in mastic to the chalk line. Nail flange as in Step 6.
6. With all sections in place, follow the splicing instructions to join bellows.
7. Counter-flashing or roofing (by others) may be installed over flanges.

Figure 4

Splicing Instructions

1. Prime metal flanges and bellows 3" (76mm) on each side of gap. Allow to dry tack free.
2. Apply a 1/4" bead of caulk along the seam where metal flange joins membrane, 3 1/2" (89mm) long at each side of the gap.
3. Remove backing from splice tab, exposing peel and stick adhesive. Install over bellows and flanges, extending tab 4" beyond metal flange.
4. Smooth out splice tab into bellows area to prevent "bridging" and to achieve a waterproof seal.
5. Adhere splice tab to metal flange and roof system, using membrane compatible adhesive.

Installation Hotline • 866.EZINPRO

Inprocorp.com • 800.222.5556 • 262.679.9010

World Headquarters S80 W18766 Apollo Drive, Muskego, WI 53150 USA

JOINTMASTER™
EXPANSION JOINT SYSTEMS