

Installation Instructions

Joint System: 787-A01

DO NOT OVER TIGHTEN
REFER TO FIGURE 5 INSTRUCTIONS

Note: Verify that the structural gap and blockout dimensions are in conformance with submittal data before beginning installation. If this is a Fire Rated Assembly, the fire barrier must be installed before the Architectural Joint System. Refer to the fire barrier instructions for specific system installation.

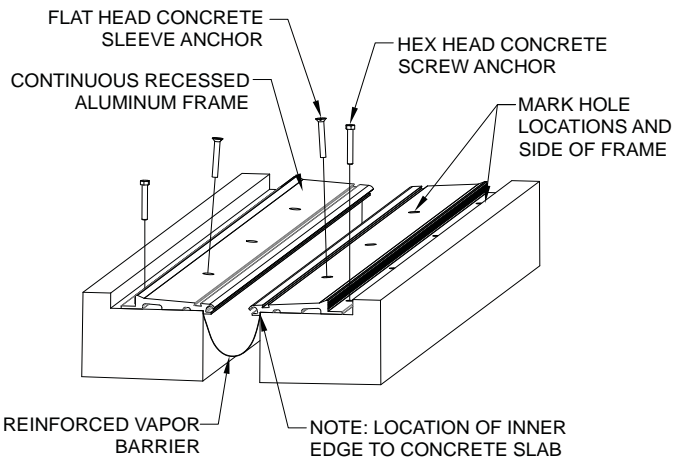

FIG. 1A

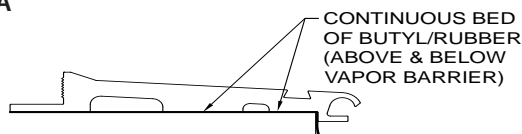

FIG. 2

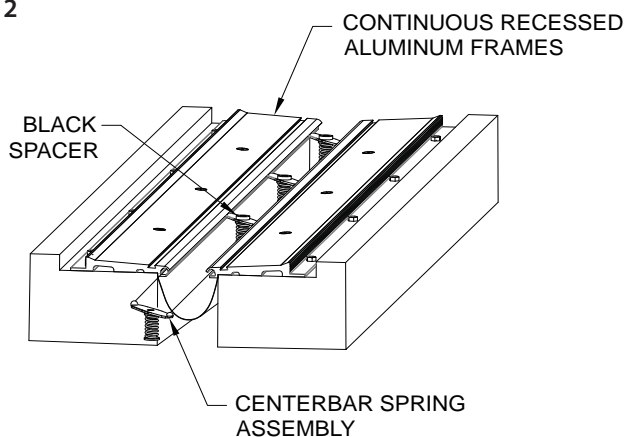
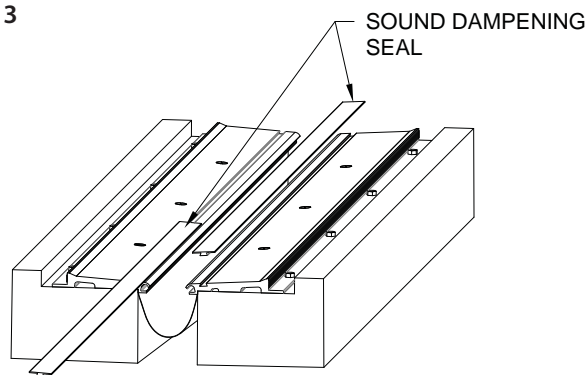

FIG. 3



1. Install the architectural joint system on a level surface within the blockout. The top of the aluminum frame should coincide with the finish floor. This may require adding leveling compound to raise the tops of the frames.

Figure 1

2. Place the recessed aluminum frames with the inner edge of the recessed frames location as shown.
3. Mark the pre-drilled hole locations and the widest side of the frames on the substrates.
4. Remove the recessed frames from the blockouts.
5. Drill all marked holes on the substrates using a 3/8" (10 mm) concrete drill bit. Holes should be drilled 2 3/4" (70mm) deep.
6. Apply a continuous bed of Butyl/Rubber on both sides of the joint to hold the vapor barrier and seal it to the concrete.
7. Install reinforced vapor barrier to align with the position of the frames (FIG1A).
8. Add a bed of Butyl/Rubber to the area of the vapor barrier resting in the blockout that will accept the frames (FIG1A).
9. Return the recessed frames in position over the drilled hole locations and secure in place with one JK131 3/8" x 2 3/4" flat head sleeve anchor for each inner hole and JK173 3/8" x 2 1/2" hex head concrete screw anchor for each outer hole.

Figure 2

10. Slide the centerbar spring assembly in the recessed frames. 7 per 10' (3 meters) frame 18" (457mm) on center. Locate each centerbar spring assembly directly in line with each countersunk hole in the aluminum cover plate. At the last section slide the correct quantity of centerbar spring assemblies in the recessed frames before mounting to the concrete slab. Suggested: Secure placement of spring centerbar assemblies with a piece of tape or backer rod.
11. Black spacer application: One spacer per centerbar spring assembly. Apply instant glue to the bottom of the spacer. Immediately attach the spacer to the top of the centerbar spring assembly. Ensuring spacer is centered over the thru hole.

Figure 3

12. Slide or press the sound dampening seal in the dovetail groove. 10" (254mm) & 12" (304mm) 787 systems have 2 dovetail grooves for seals.

IPC.1562/REV.7

Installation Hotline • 866.EZINPRO

Inprocorp.com • 800.222.5556 • 262.679.9010

World Headquarters S80 W18766 Apollo Drive, Muskego, WI 53150 USA

JOINTMASTER®
EXPANSION JOINT SYSTEMS
A DIVISION OF INPRO®

Installation Instructions

Joint System: 787-A01

DO NOT OVER TIGHTEN
REFER TO FIGURE 5 INSTRUCTIONS

FIG. 4

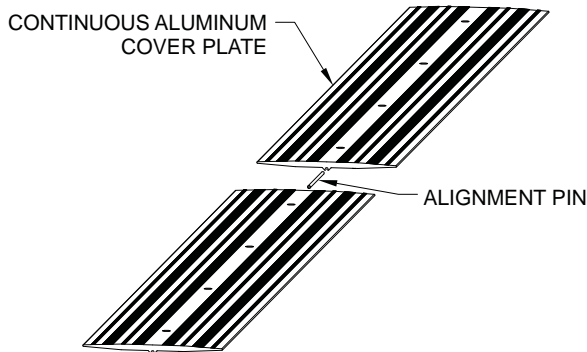

Figure 4

13. Apply instant glue in the alignment pin groove 3" (76mm) in from the end. Immediately push the alignment pin 3" (76mm) in the aluminum cover plate.
14. Take the next section of cover plate and push on the alignment pin so both cover plates are together.

FIG. 5

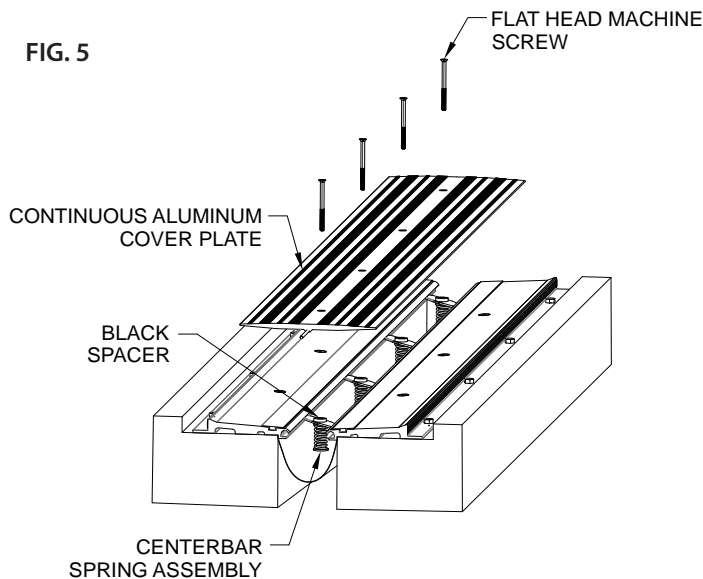

Figure 5

15. Place the aluminum cover plate countersink over each centerbar spring assembly hole. Use one JK176 3/8"-16 x 4" flat head machined scrow for each countersunk hole. By hand, thread thru the centerbar spring assembly until the screw is fully seated in the countersink. Mark the screw head and turn the screw clockwise 6 complete rotations. **DO NOT OVER TIGHTEN!** This provides 19# (8.6kg) of preload pressure for the spring.

FIG. 6

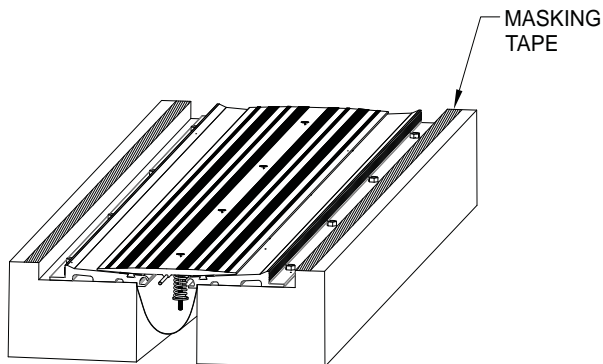

Figure 6

16. Use masking tape on the concrete slab next to the blockout.
17. Backfill the blockout with elastomeric concrete level with the adjacent concrete slab.
18. Remove masking tape from the concrete slab.
19. Clean the exposed surfaces with a non-solvent cleaner, such as 409, as required.

Figure 7 (787-A01 Completed installation)

