

Installation Instructions

Joint System: 801-A07/A09

Note: Verify that the structural gap is in conformance with submittal data before beginning installation. If this is a Fire Rated Assembly, install the fire barrier before the Architectural Joint System. Refer to the fire barrier instructions for specific system installation.

FIG. 1 (801-A07 WALL TO WALL SHOWN)

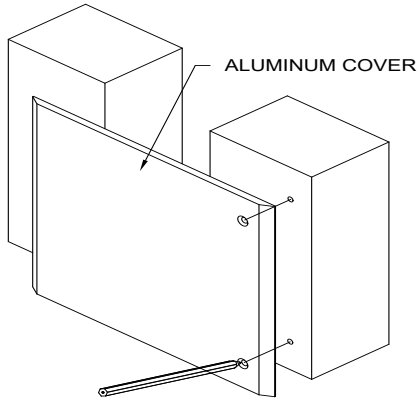

FIG. 1A (801-A09 WALL TO CORNER SHOWN)

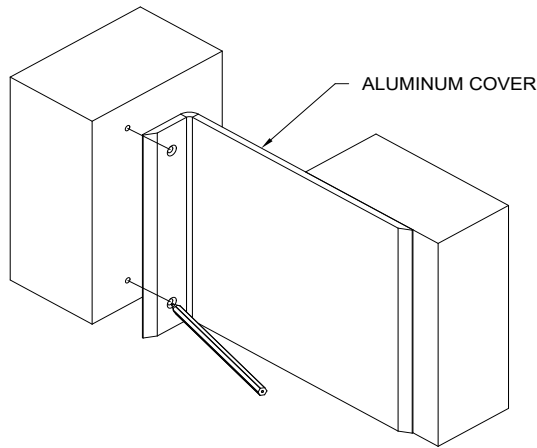
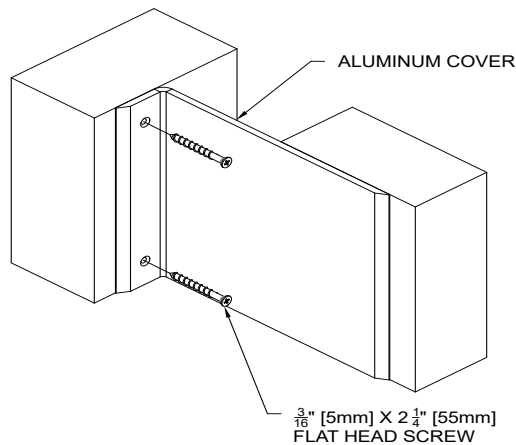
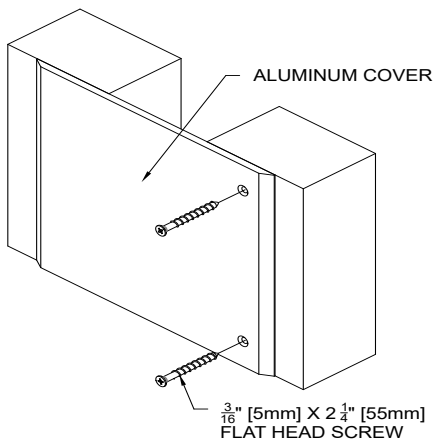

FIG. 2



IPC.3133/REV.1

1. Install the architectural joint system on a level wall surface. This may require adding compound to the substrate to provide a smooth level mounting surface.

Figure 1

2. Cut the aluminum plates to the desired length, if required.
3. Place the plates over the structural gap.
 - 3a. For wall to wall (A07) condition, plate should be centered over the structural gap keeping the predrilled mounting holes on one side. (See Figure 1)
 - 3b. For floor to wall (A09) condition, should be placed firmly against the finished wall. (See Figure 1A).
4. Mark the pre-drilled hole locations on the substrate.
5. Remove the plates.

Figure 2

6. Drill all marked holes on the substrate using a 1/8" [3mm] drill bit and drill 2-3/8" [60mm] deep.
7. Return the plates into position over the drilled hole locations and secure in place with JK002 3/16" [5mm] x 2-1/4" [55mm] flat head Tapcon screws.

Installation Instructions

Joint System: 801-A07/A09

Note: Verify that the structural gap is in conformance with submittal data before beginning installation. If this is a Fire Rated Assembly, install the fire barrier before the Architectural Joint System. Refer to the fire barrier instructions for specific system installation.

FIG. 3 (801-A07 COMPLETED INSTALLATION)

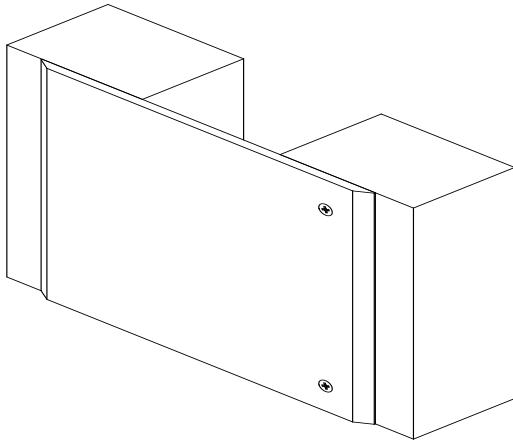

Figure 3 & 3A

8. Clean the exposed surfaces with a non-solvent cleaner, such as 409, as required.

FIG. 3A (801-A09 COMPLETED INSTALLATION)

