

Installation Instructions

F520 Fire Barrier Floor to Floor and Wall to Wall Top Mount

STORE AND INSTALL BLANKETS SUCH THAT THE PRODUCT REMAINS DRY.

NOTES:

1. Verify that the structural gap and blockout dimensions are in conformance with submittal data before beginning installation. Certification of this product was completed by Guardian and Intertek Testing Laboratories. Product must be installed in accordance with these Installation Instructions.
2. For vertical (wall) installations, for single sided and double sided blankets available. For single sided product, ensure drape of blanket faces "potential threat" side of wall.
3. If job site specific conditions exist, these general installation instructions do not take place of an Engineering Evaluation if required. Any modifications made to the product without documented manufacturing direction will void the warranty.
4. F520 Fire Barrier is delivered pre-assembled. Transitions/directional changes must be installed first.

Fire Caulk Disclaimer:

Inpro provides 1 or 2 tubes of fire caulk (depending on order size) at no charge. Should additional caulk be required, due to project or site complexity, additional caulk to be provided by others.

Figure 1- General Installation Workflow

1. Place the fire barrier into the expansion joint, F520 Fire Barrier has a 12" (305mm) overlap at each end. One end is the male and the other is the female. Always secure the female with fasteners in each upper corner as depicted.
2. On the first section remove the male end and slide it into the wall. Install the next section, nesting the male into the female end tightly and secure with hardware appropriate to the substrate.
3. Flanges are expanded metal. Ensure flanges are pressed tight and held flat to the substrate. Pour a leveling compound over the flanges to ensure a flush blockout base if necessary.
4. Utilize hardware appropriate to the substrate (supplied by others) with a maximum spacing of 12" (305mm) O.C. Recommended hardware for various conditions are:
 - Floor - 1/4" (6mm) x 1 3/4" (44mm) concrete/wood screw with washer
 - Wall - 3/16" (5mm) x 2 1/2" (64mm) concrete/self drilling screw with washer

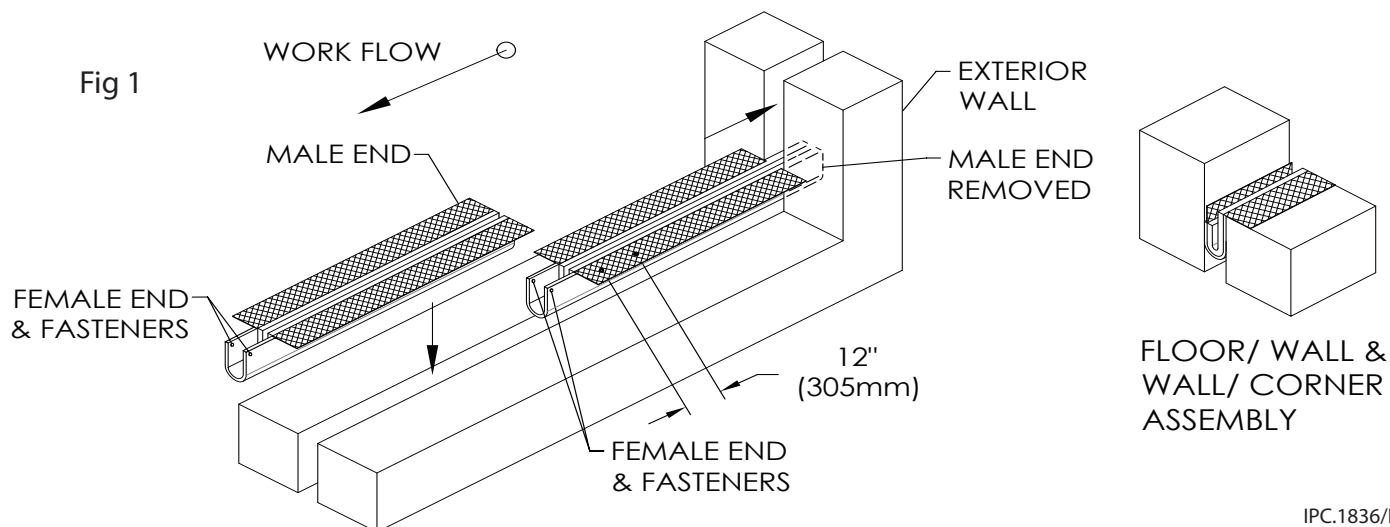

IPC.1836/REV.6

JOINTMASTER® Expansion Joint Systems

inpro.com • 800.222.5556 • 262.679.9010

World Headquarters S80 W18766 Apollo Drive, Muskego, WI 53150 USA

Installation Hotline: 866.394.6776

inpro®

Installation Instructions

F520 Fire Barrier Floor to Floor and Wall to Wall Top Mount

Figure 2- Transition Installation Workflow

5. Begin by installing the female-ended transition.
6. Secure each 12" (305mm) flange into place with hardware to the appropriate substrate. Always install vertical blanket with the female end up as shown in Fig. 2.
7. Continue fire barrier installation per Fig. 1.

Fig 2

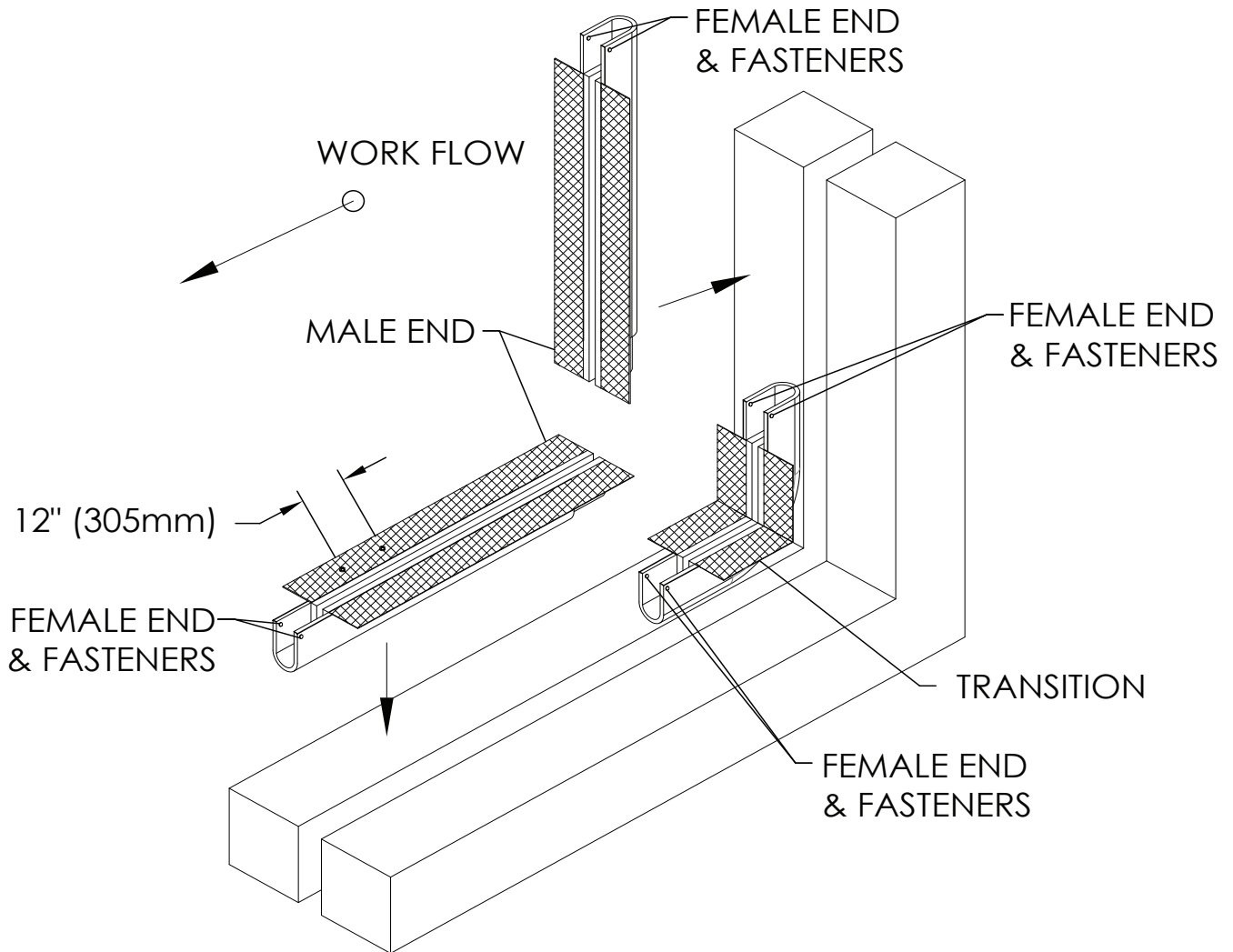

Installation Instructions

F520 Fire Barrier Floor to Floor and Wall to Wall Top Mount

Figure 3- Vertical Intersection

8. Remove the male end of the verticle fire barrier. Always install vertical blanket with the female end up.

9. Next measure the depth of (Dim A) and the inside bellows (Dim B). Cut a "V" shape to match the space within the blanket. Flange trimming may be required.

10. Install the modified end into the throat of the floor and insert the fire barrier into the wall. Be sure there are no voids between the two. Fire caulk at connection point to ensure no air gap exists. Fig. 3a

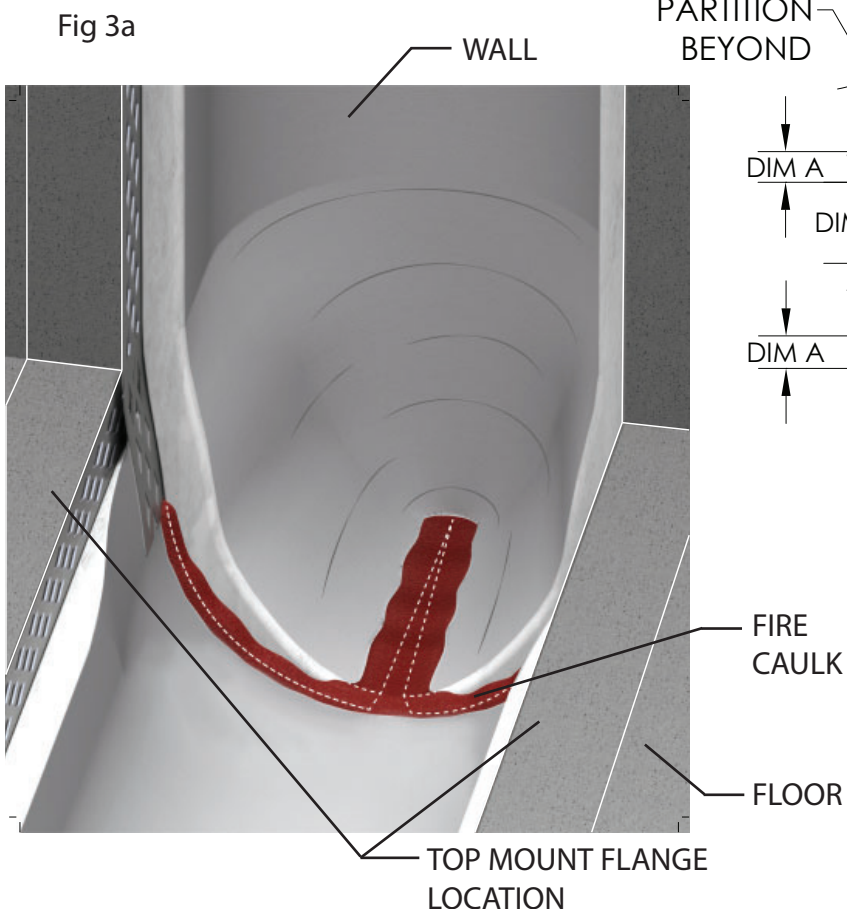
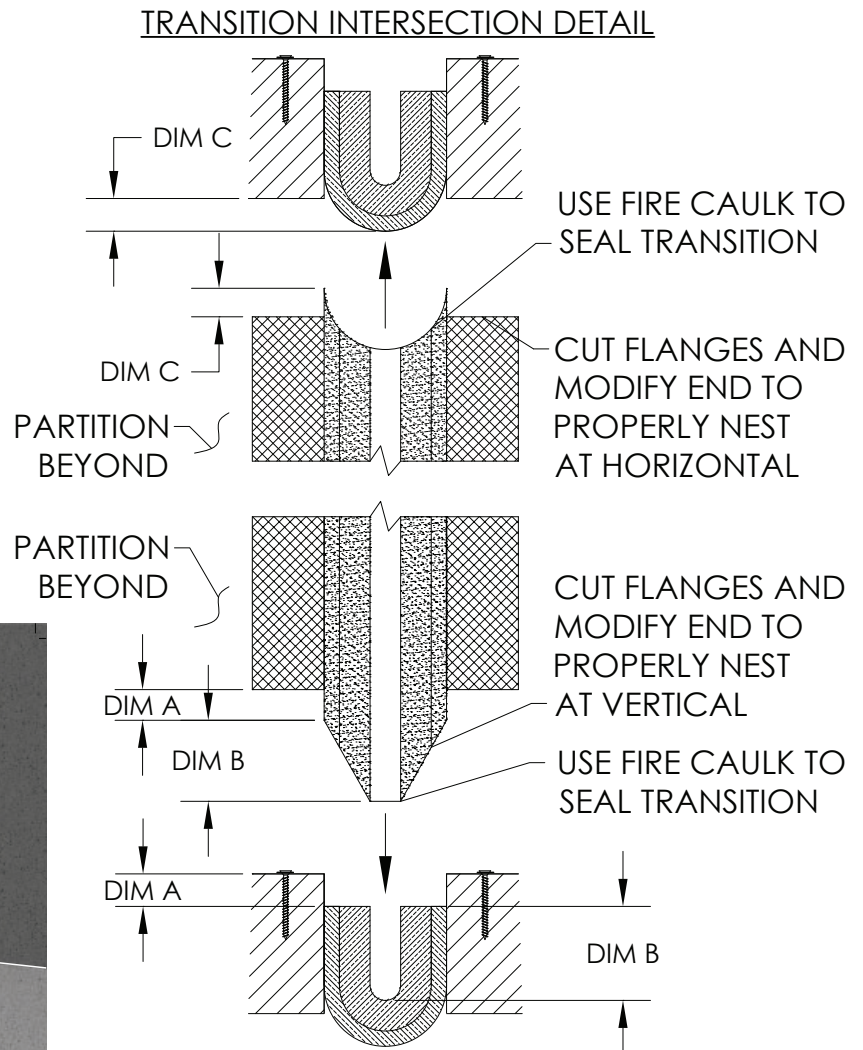

Fig 3



Installation Instructions

F520 Fire Barrier Floor to Wall and Wall to Corner Top Mount

Figure 4- Field Specific Lengths Work Flow

11. In the event a project requires a specific length, a female end can easily be recreated in the field to facilitate the next male end connection.
12. Measure the needed length from the edge of the flange to the other edge of the flange. Mark it on both sides.
13. Measure back 12" (305mm), using a razor remove the inside layer of white blanket material exposing the flanges (see Fig 4a). Remove the pins and cut the flanges off. The 1/2" (13mm) thick outer fire blanket will remain with the section.
14. In the female end install the 4 new pins/washers and bend the pins over.
15. Nest the 24" (610mm) male end into both female ends and fasten.

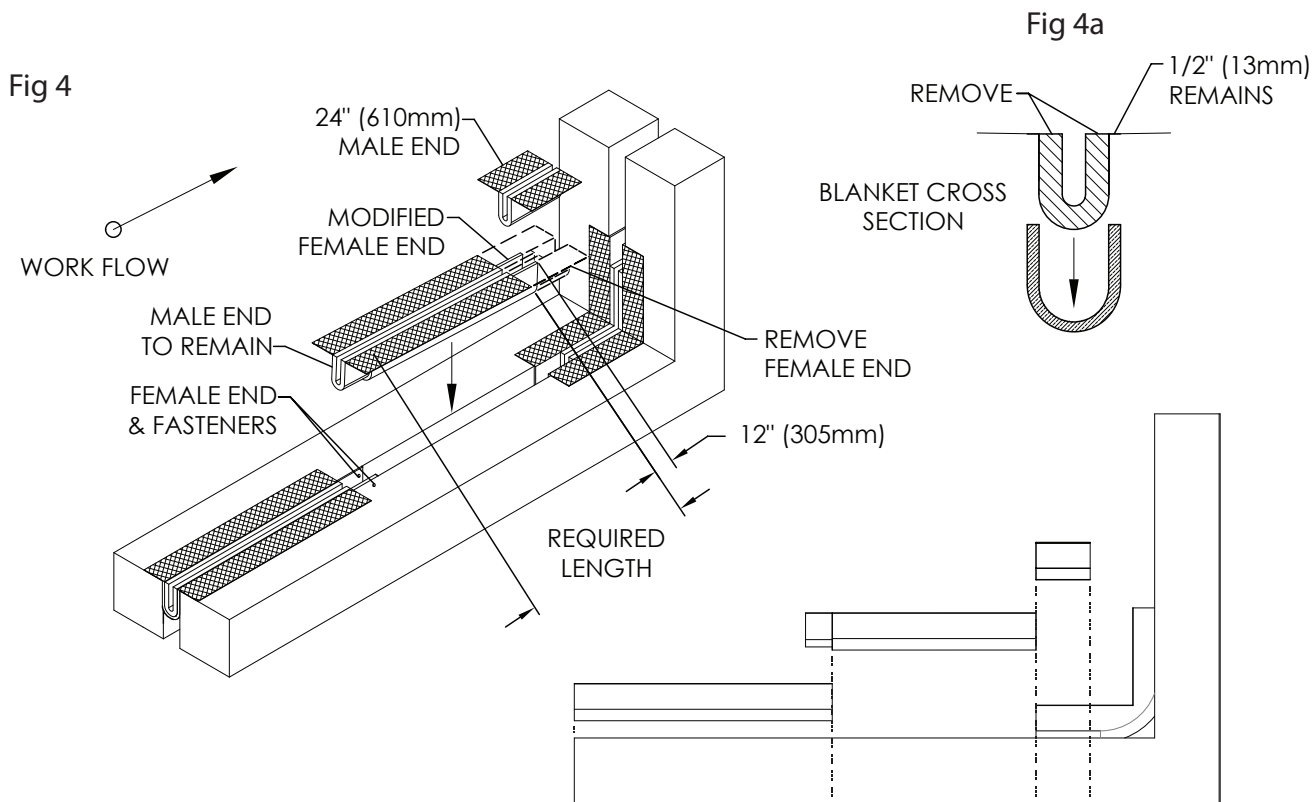

Installation Instructions

F520 Fire Barrier Floor to Wall and Wall to Corner Top Mount

Figure 5- Field conditions of whole fire blanket lengths Work Flow - increments 10'(3.1m) or 4'(1.2m)

16. In these conditions you must remove the first male end and use it in the last female end.
17. Remove the pins and cut the fire blanket in line with the edge of the flange. Set male end aside for later installation.
18. Install all the sections except for the last one.
19. Take the male end that is set aside and nest into the last female end.
20. Install the new pins/washers and bend the pins over.

Fig 5

